

About Quai d'Orsay

Drawing on over 30 years of experience and expertise, vast material knowledge, and a profound passion for art history, Quai d'Orsay was founded under the initiative of Jean-Louis Deniot, with the aim of creating in the tradition of French decorative arts, cultivating free artistic expression and translating gesture in design. Each year, Quai d'Orsay produces a select number of designs which illustrate this philosophy.





From Quai d'Orsay to rue de Verneuil

From his interior design agency at 39 Quai d'Orsay, facing the Seine and the French Ministry of Foreign Affairs, Jean-Louis Deniot has, for more than three decades, conceived residences for an international clientele — interiors shaped by rigor, craftsmanship, historical reverence, and a certain sense of play.

Located at 39 rue de Verneuil, in the historic Carré Rive Gauche district, the Quai d'Orsay showroom brings this sensibility into a dedicated gallery for collectible furnishings, lighting, and home accessories conceived under the artistic direction of Jean-Louis Deniot.

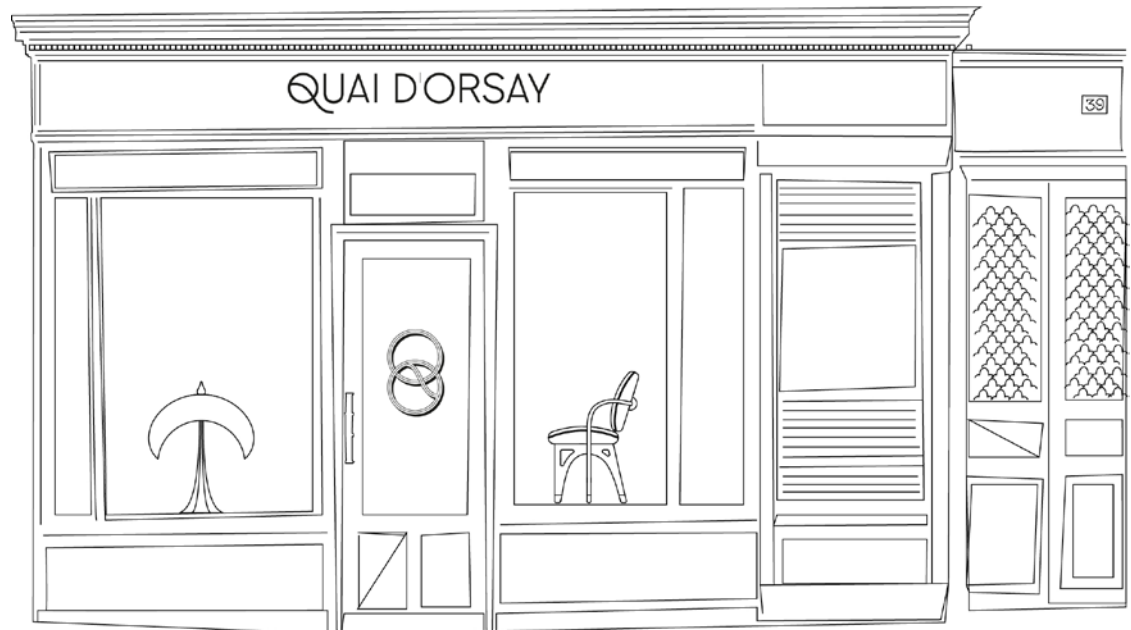

About the designer

Jean-Louis Deniot works in the French tradition of the ensemblier-décorateur, shaping homes as complete, thoughtful worlds. From floor plans to doorknobs, façades to furniture, he approaches design as a cohesive whole. Deeply passionate about the history of art and architecture, he brings this perspective to residences across Paris, London, New York, Bangkok, Athens, Capri, and beyond—creating spaces that feel both cultivated and quietly lived-in.



Jean-Louis Deniot



About the collection

This collection is inspired by Paris as it really is—a city where medieval streets sit beside Art Deco façades, where Gothic and Brutalist styles quietly and harmoniously coexist. Its eclectic character comes from that layering of time, from things shaped slowly through use, accumulation, and real stories; the kind of beauty that isn't rushed or polished away, but built up over years. In that sense, the collection is a small ode to Paris: thoughtful, enduring, and grounded in history.

le GESTE

*Forms shaped by movement,
instinct, and hand.
A study of silhouette, proportion,
and the expressive language of
gesture.*



QUAI D'ORSAY

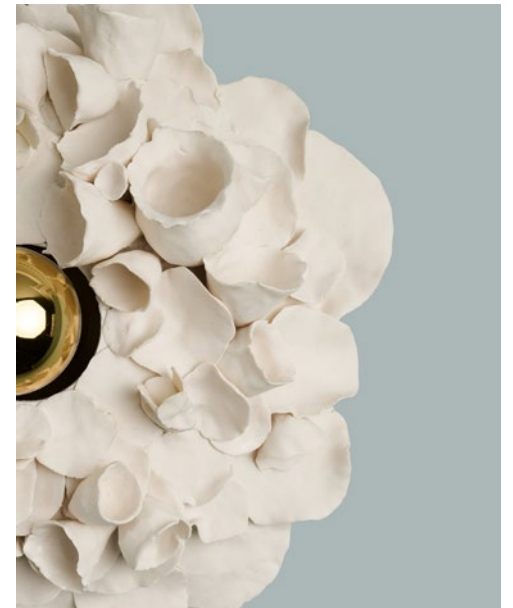
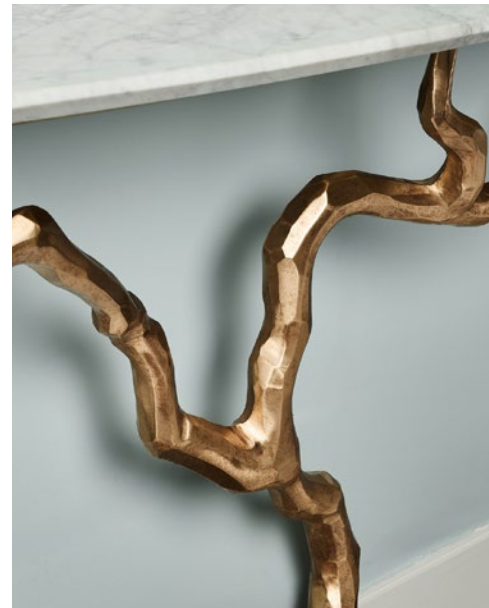
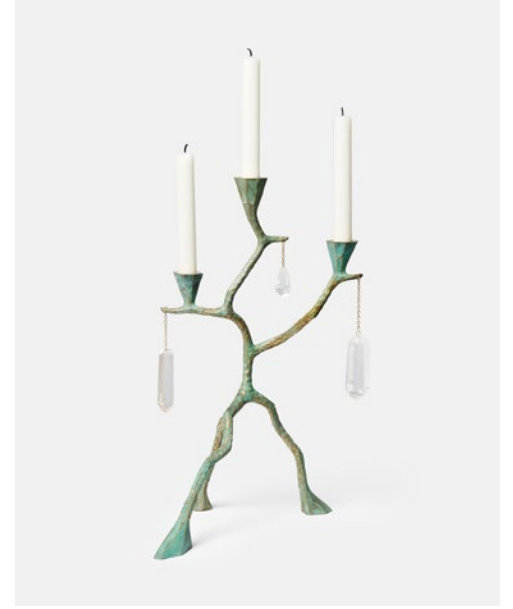

la MATIÈRE

*Bronze, porcelain, alabaster,
lacquer, textured glass — materials
chosen for their depth, tactility,
and capacity to age with elegance.*



QUAI D'ORSAY

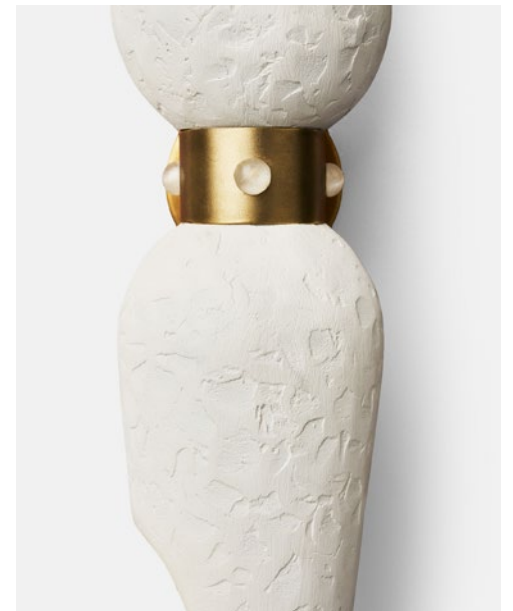
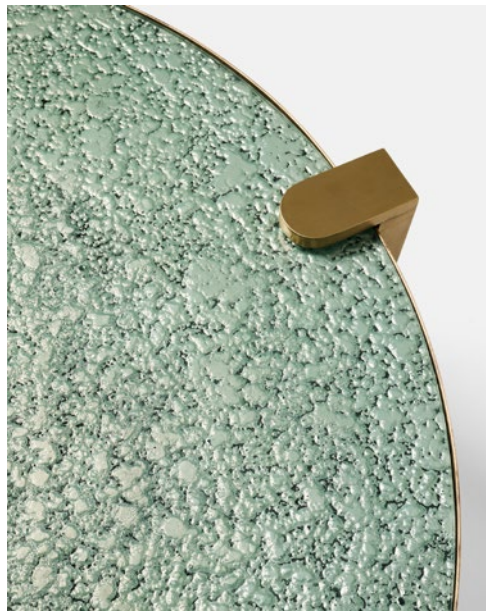

la VILLE

*Paris as a layered composition
of histories, atmospheres, and
architectural coexistences — where
rigor and eclecticism quietly meet.*

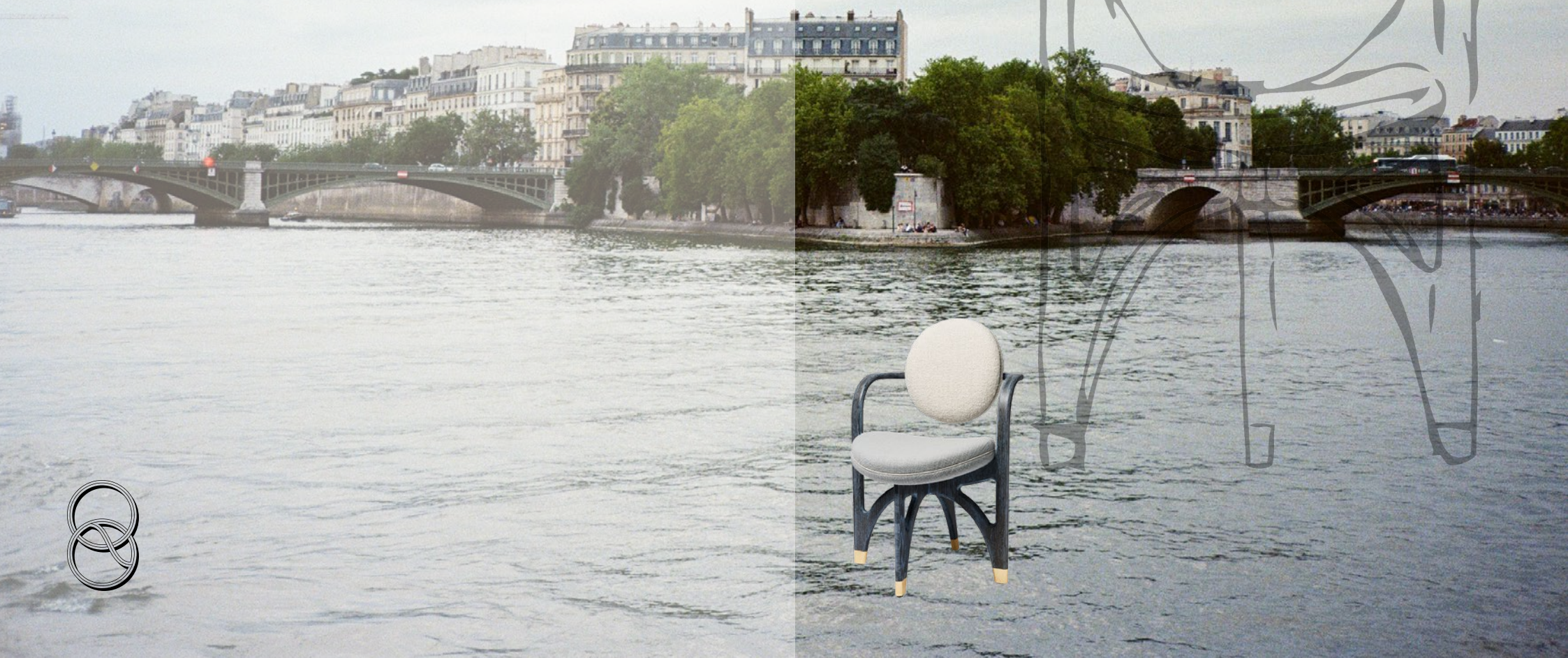

QUAI D'ORSAY



les LIGNES

Drawn structures, repeated rhythms, and architectural forms distilled to their essential lines.

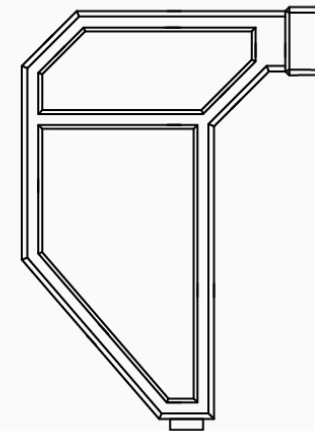
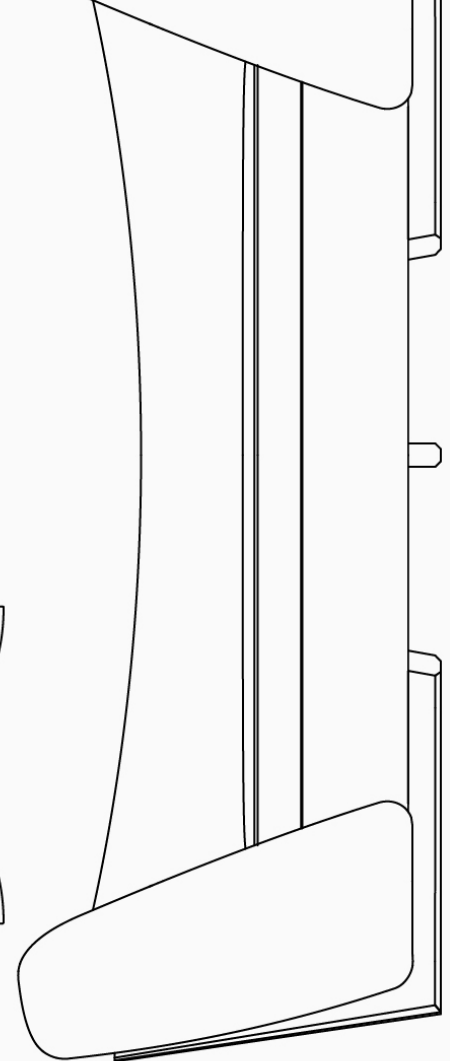
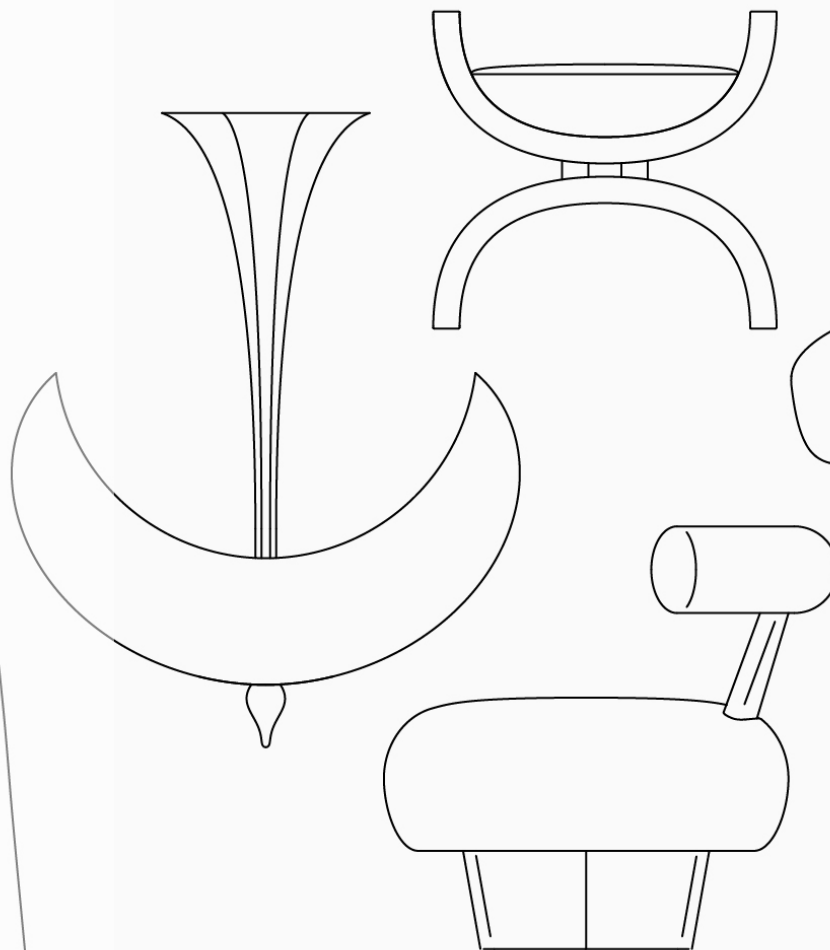
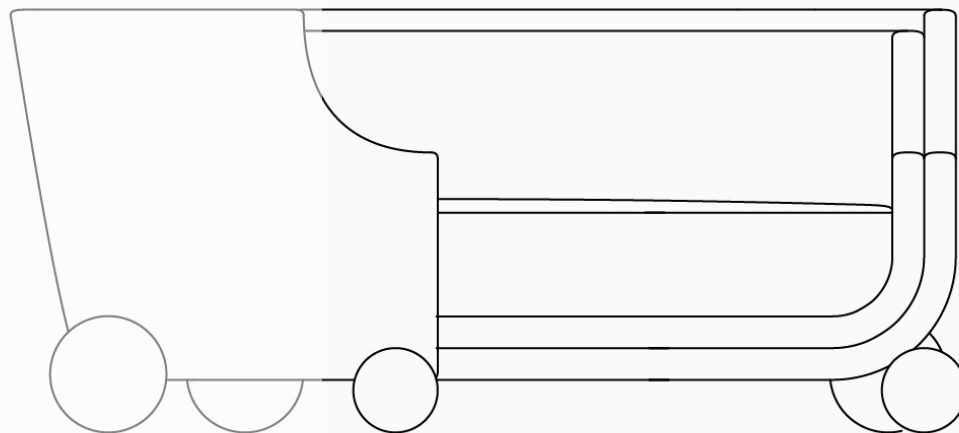
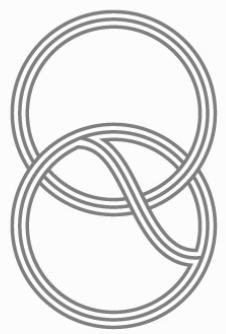
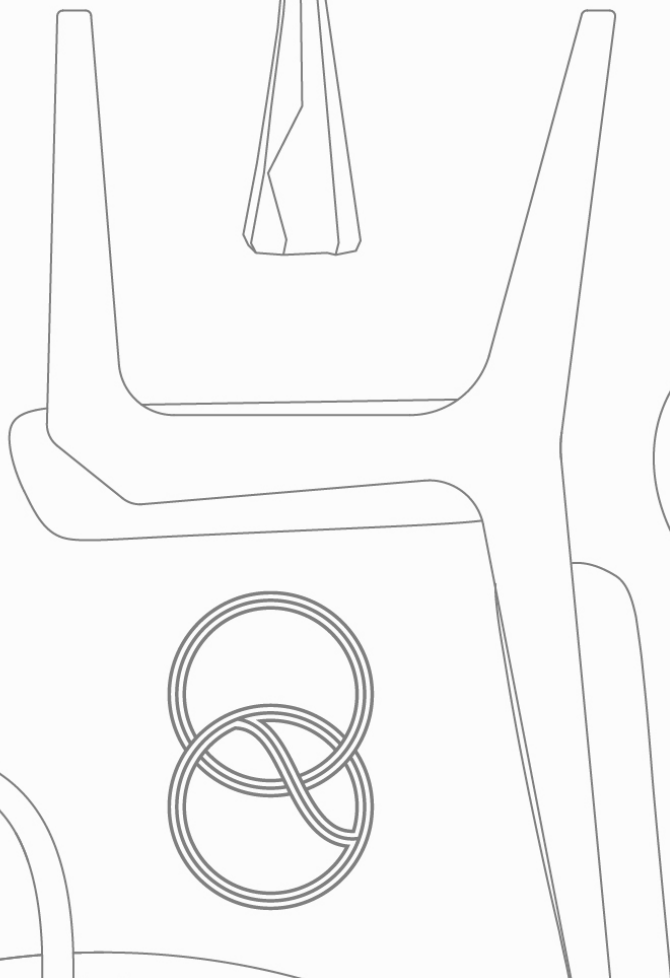
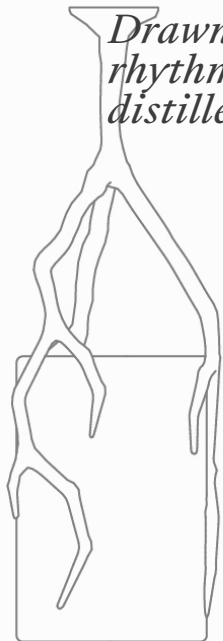

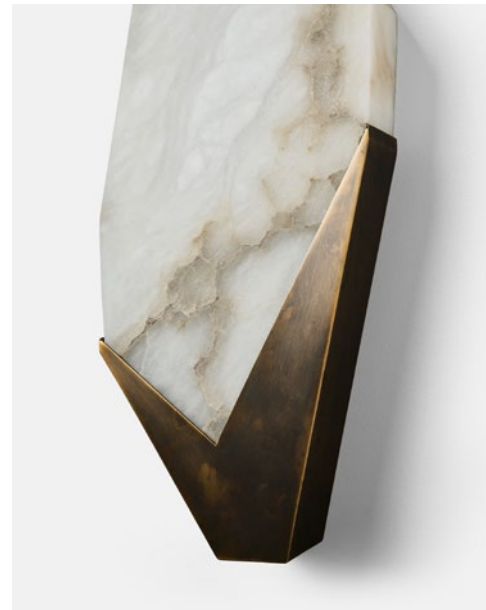



la COLLECTION

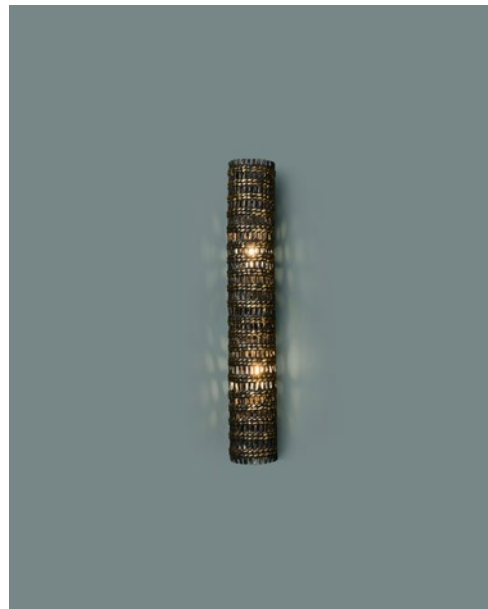

QUAI D'ORSAY

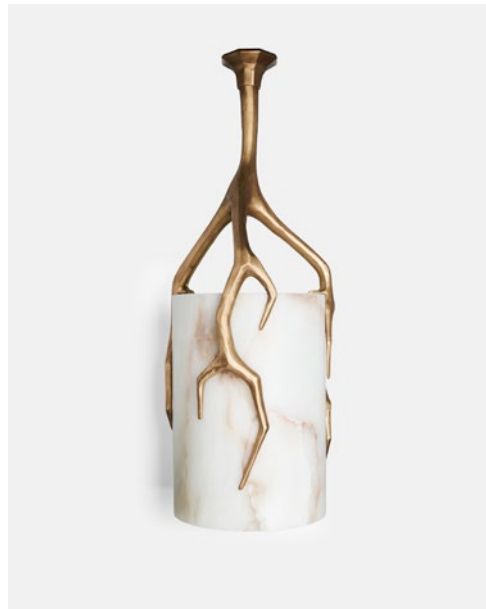
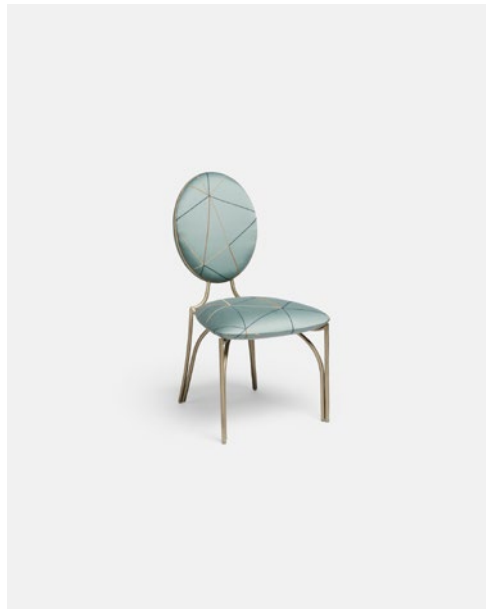
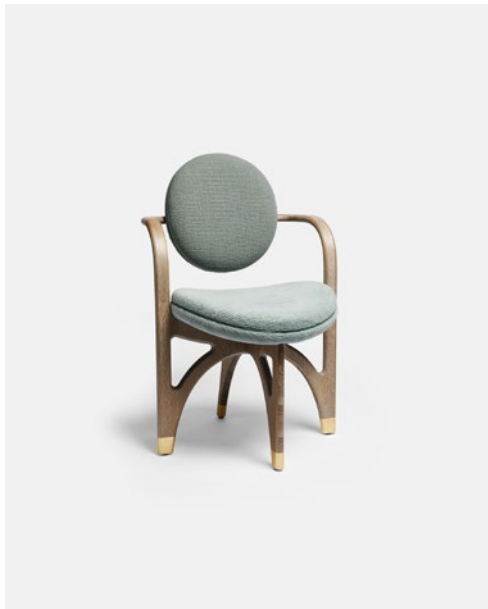



QUAI D'ORSAY

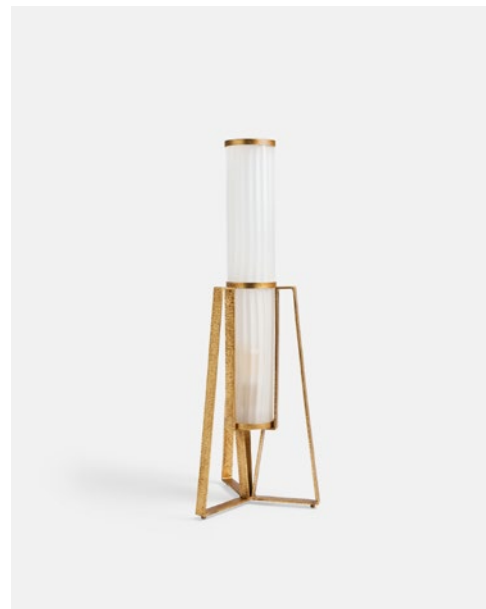





Quai d'Orsay & Lesage Intérieurs

Handcrafted in Paris, the fabrics for these decorative pillows come from Lesage, historic French maison founded in 1924, known for its tweed and artistic embroidery for haute couture fashion houses.



QUAI D'ORSAY

mobilier

MERCI

•

Website:
quaidorsay.com

Showroom:
39 rue de Verneuil, Paris 75007

Inquiries:
grace@quaidorsay.com
+33 6 49 50 14 99 / +33 7 85 05 42 07

Instagram:
[@quai.dorsay](https://www.instagram.com/quai.dorsay)

Opening September 2026